

# SECTIONAL DOORS

**INDUSTRIAL**





### RECOGNIZED QUALITY

Flexidoor sectional doors fulfil all the European standards for safety requirements. All the safety components are an integral part of our door, giving our customers the guarantee that our products are designed to ensure safety and well-being.



### TECHNICAL ASSISTANCE

Flexidoor has a specialized and skilled technical team which offers you all the necessary support since the planning up to the installation phase. This way, safety will be at your side during the time of work execution.



### WELL-BEING IS ALWAYS ON OUR MIND!

Nowadays aesthetic appearance of our homes has a huge importance, even because it is fundamental that we feel good in what is, after all, our home. So we have at your disposal different types of sectional doors with the most varied settings so that you can always get what you want.





# SECTIONAL DOORS PANELS



## FLEXIDOOR

Flexidoor considers the innovation a form of learning about the new ways of offering a better product to our customers. As well as the continuous efficiency gains demand with the objective of creating value for the entire organization and its partners.

Thus, the day by day R&D Department

work is filled with new challenges that we believe define who we are.

This is our identity.

This is our future.



# PANEL

## THICKNESS



## Technical Specifications

- Heat transfer coefficient:
  - Panel 610 mm with seal:  $U= 0.76 \text{ W/m}^2\text{K}$
  - Panel 500 mm with seal:  $U= 0.80 \text{ W/m}^2\text{K}$
  - Panel 610 / 500 mm without seal:  $U= 0.53 \text{ W/m}^2\text{K}$
- Closed cell content:  $\pm 94\%$
- All panels are lined internally and externally with a protective PVC film
- Density:  $\pm 45 \text{ kg/m}^3$
- Adhesive strength:  $\pm 0.10 \text{ MPa}$
- Compressive strength:  $\pm 0.13 \text{ MPa}$
- Compressive Modulus of Elasticity:  $\pm 2.68 \text{ MPa}$
- Thermal conductivity:  $\pm 0.14 \text{ W/mk}$



# GROOVE PANEL



GROOVE

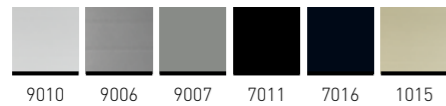

OTHER AVAILABLE RAL COLOURS

**NOTE:** Finishing and colours are only available on the 40mm panel.

# STUCCO PANEL



STUCCO



OTHER AVAILABLE RAL COLOURS

# FLAT PANEL



WHITE FLAT

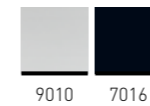

OTHER AVAILABLE RAL COLOURS

**NOTE:** Finishing and colours are only available on the 40mm panel.

# MICRO RIB PANEL



MICRO RIB



OTHER AVAILABLE RAL COLOURS

**NOTE:** Finishing and colours are only available on the 40mm panel.









# INDUSTRIAL SECTIONAL DOORS



## FLEXIDOOR

The Flexidoor Industrial sectional doors can be adapted to any kind of building due to the multiple assembly types. These along with durability and design, are important factors that can decide the choice of our products.

### Industrial sectional door main characteristics:

- Side and intermediate hinges more robust and strong
- Industrial Embedded Handle
- Double side hinges and long rollers from 5200mm
- Panel reinforcements from 5250mm
- Spring bumpers

# WINDOWS



## Windows PVC frames



Rectangular acrylic window with black frame  
Width: 680 mm • Height: 373 mm



Oval acrylic window with black frame  
Width: 663 mm • Height: 343 mm

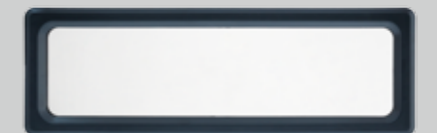

Small rectangular window with black frame  
Width: 610 mm • Height: 203 mm



# BIG ALU



## **BIG ALU**

With different types of manufacturing, this door is constituted by full vision aluminium panels with Acrylic or double glass. The BIG ALU door is the perfect solution for increased natural light and improved visibility in the area in which they are applied.

In the BIG ALU doors we can combine the normal sandwich panel with full vision aluminium panels, and also we can replace the glazing area for aluminium perforated plates to increase air circulation.

Contact us for more information.





# PANELS BIG ALU

## FINISHING

The Flexidoor range of panels with aluminium frame offers a complete solution for your glazed panel needs. The aluminium profile ensures a high quality, durable and aesthetically pleasing transparency that can be integrated with our range of 40 mm sandwich panels.

- With-finger safe system.
- Available for doors up to 7 m wide.

- Panel height up to 735 mm.
- Panels available in anodized finish or any RAL colour.
- 5 types of glazing: single or double acrylic, laminated glass, double glass with air box and perforated aluminium plates.

Your sectional door can include one or more BIG ALU Panels.









# BIG ALU

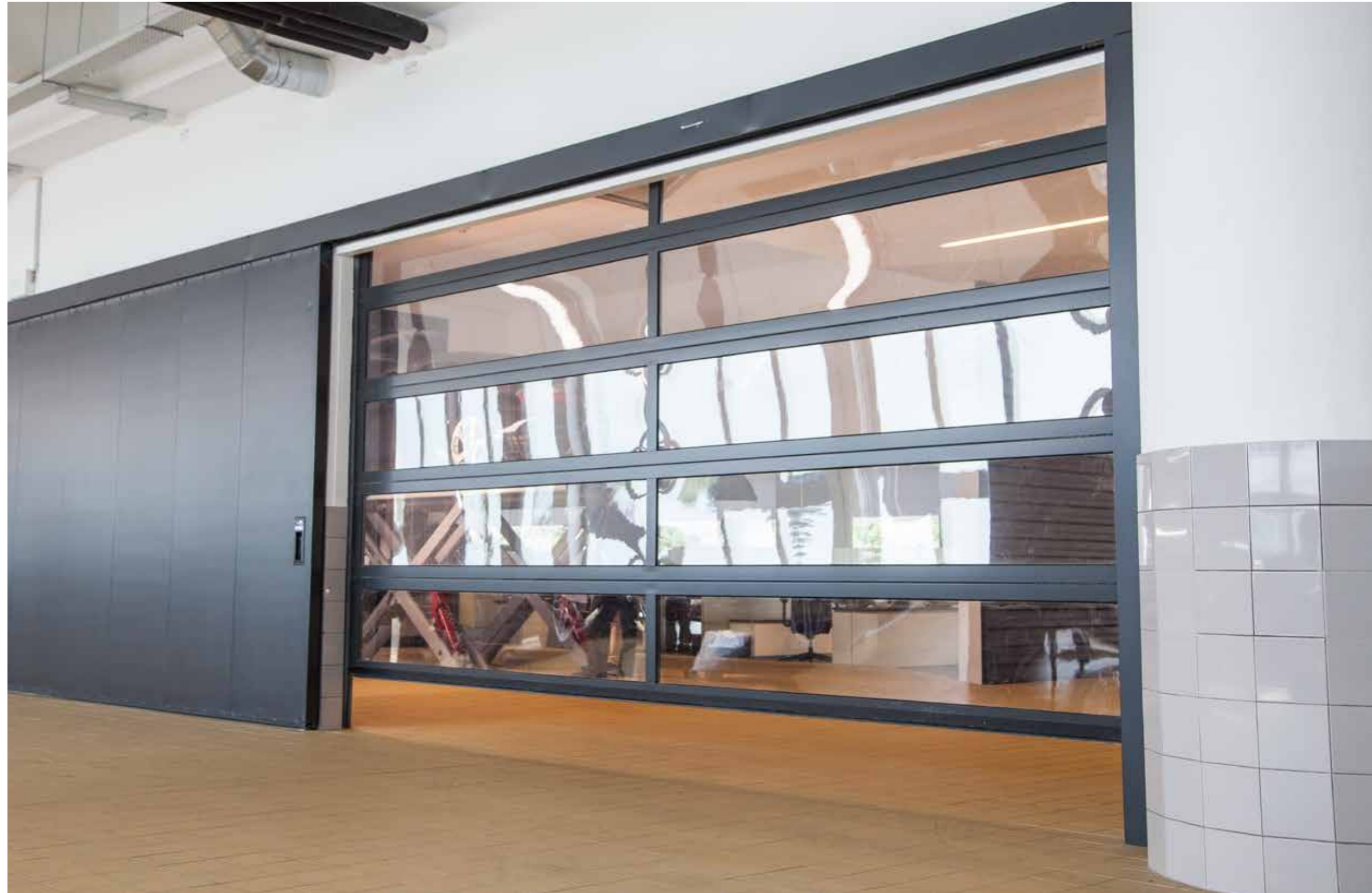



# WIND RESISTANCE

## WIND RESISTANCE

Panel	PAIGRO	PAIWF	PAIWF1F PAIWF1FL	DARKFLAT	PAIFRA	PAIMP	PAIGROALU	FLEXISTEP	PAIGRO 22	PAIBIGICE 80mm	PAIMP	BIGALU
Width ..... 12000										2	7000	2
10000	2 Rx2	2 Rx2				2 Rx2				2 Rx2	4845	5 2 R
9000	2 Rx2	2 Rx2				2 Rx2				2 R	4500	5 3 R
7000	2 Rx2	2 R				2 Rx2				2	4000	5 R
6500	2 R	2 R				2 R				2		
6220	2 R	2 R	2 Rx2	2 Rx2		2 R	2 Rx2			2		
5500	3 Rx2	3 2 Rx2 R	2 R	2 R		3 2 Rx2 R	2 R			2		
5250	2 R	2 R	2 R	2 R		2 R	2 R			2		
5200	2	2	2	2		2	2			2		
5000	2	2	2	2	2	2	2	2		4		
4500	3 2 R	3 2 R	2	2	2	3 2 R	2	2		4		
4000	4 2 R	3 4 R	2	2	3	4 2 R	2	2		4		
3500	3	3	3	2	4 2 R	3	2	2		4		
3200	3	3	3	2	2	3	2	2	2	4		
3000	5	5	5	5	5 3 R	5	5	3 2 R R		5		
2500	5	5	5	5	5 3 R	5	5	3 2 R		5		
2400	5	5	5	5	4	4	5	5 2 R		5		
.....												

## LEGEND

PAIGRO	Groove type panel
PAIWF	White Flat panel
PAIWF1F / PAIWF1FL	White Flat panel with 1 rib
PAIFRA	Frame type panel
PAIMP	Micro Rib panel
PAIGROALU	Aluminium panel
PAIGRO 22	22mm Groove panel
R	Reinforcement panel

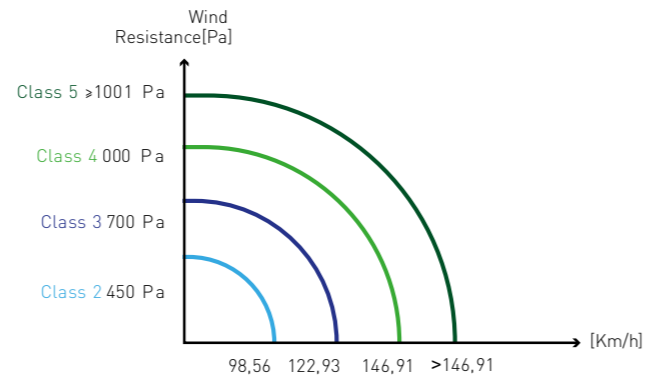

# HEADROOMS

## HIGH LIFT

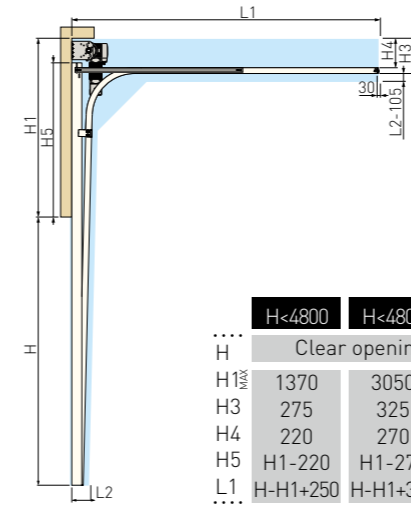

	H<4800	H<4800	H<6000
Clear opening height			
H1 <sub>max</sub>	1370	3050	4100
H3	275	325	405
H4	220	270	350
H5	H1-220	H1-270	H1-350
L1	H-H1+250	H-H1+300	H-H1+380

## HIGH LIFT WITH LOW SYSTEM

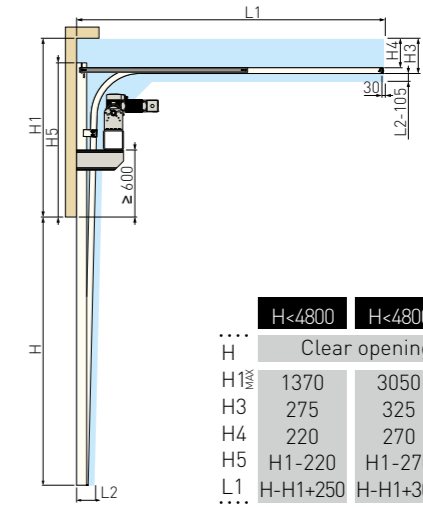

	H<4800	H<4800	H<6000
Clear opening height			
H1 <sub>max</sub>	1370	3050	4100
H3	275	325	405
H4	220	270	350
H5	H1-220	H1-270	H1-350
L1	H-H1+250	H-H1+300	H-H1+380

## VERTICAL LIFT

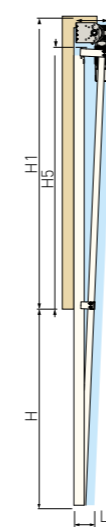

	H<3300	H<6000	H<7000
Clear opening height			
H1	H+240	H+300	H+370
H5	H	H	H

## VERTICAL LIFT WITH LOW SYSTEM

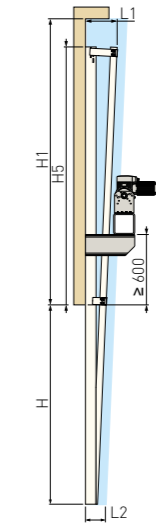

	H<3300	H<6000	H<7000
Clear opening height			
H1	H+240	H+300	H+370
H5	H	H	H

## NORMAL LIFT WITH INCLINATION

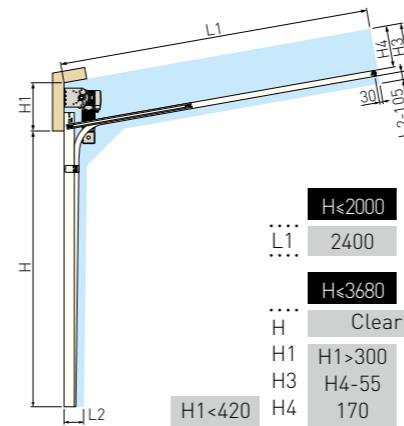

	H<2000	H<2400	H<2400
L1	2400	2800	H+600
Clear opening height			
H1	H1>300	H1>350	H1>550
H3	H4-55	H4-55	H4-55
H4	170	170	170
H4	270	270	270

## HORIZONTAL VIEW

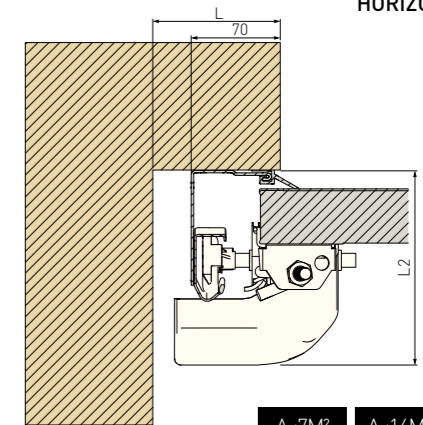

	A<7M²	A<16M²	A>16M²
L1	100	120	100
L2	135	160	200

Thermal Resistance: 1,0 [W/m²K] // \*Door 5x5m



# LOGISTICS SYSTEMS



## LOGISTICS SYSTEMS

Flexidoor loading systems are the ideal solution to simplify the entire loading and unloading processes. This solution has different types of products that include dock levellers, dock shelters, tunnels and scissor tables.

These sets of integrated solutions contribute to the perfect balance between agility, functionality and safety.



## THE MOST ACCURATE SOLUTION.

Simple, quick and functional, it is without doubt the perfect solution for any loading bay. Its hydraulic tilting mechanism and folding lip enables the dock leveller to cover the gap and height between the loading bay and the truck, allowing it to rest firmly on the loading bay, to ensure a safe and efficient loading and unloading process. The standard colour is RAL 7016.



The RH1 dock leveller has three parts:

- A platform with an upper sheet of tear plate with thickness of 6/8 mm and a set of laminated profiles and protective side panels.
- A lip made of tear plate sheet with a thickness of 13/15 mm. The lip is folded and milled at the end, to fit onto the truck and to ease the passage of the forklifts.
- And the inferior structure formed by laminated profiles upon which the platform and hydraulic assembly are installed.

Safety is an essential requirement for any professional. For this reason, all Flexidoor levellers have diverse safety systems:

- An emergency stop activated by a section switch or zero voltage.
- An anti-fall safety valve inside the hydraulic cylinder.
- Fixed and mobile side panels that serve as a foot guard.
- A platform with an upper surface anti-fall tear plate.
- Safety signals in form of stickers on moving parts.
- Safety bar to prevent the leveller from closing during maintenance work.

# RH1 DOCK LEVELLER



# RH1

## EMBEDDED PIT TYPE

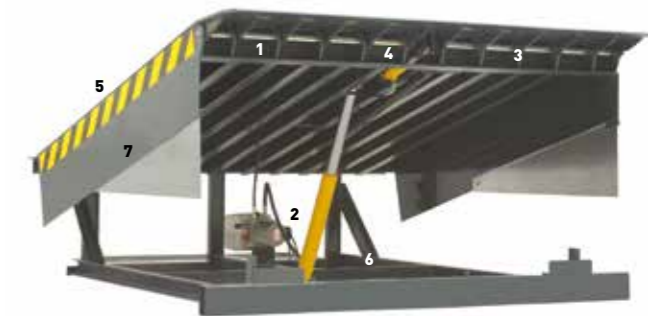

**1** A construction system with self-cleaning flat hinges made with ST-52 laser-cut steel for perfect alignment and resistance. In addition, it is designed to prevent the moving parts of the leveller from maladjustment due to grime.

**2** The hydraulic equipment comprises: a 1.0 CV electric motor, hydraulic pump with a flow rate of 5 l/m and a 7 litre tank with an oil level viewer, safety electro valve, elevation cylinder with a Ø50 mm rod, lip cylinder with a Ø30 mm rod and hydraulic hoses.

**3** All the shafts are protected from corrosion by a passivated, zinc electrolytic coating.

**4** Centring system between lip and bay with nylon dividers to ensure that the lip is always in the correct working position.

**5** One characteristic feature of the RH1 is that when lying on the truck base, it adapts to the raising and lowering of the truck caused by loading and unloading, thanks to its lateral inclination.

**6** The anti-fall safety valve in the hydraulic cylinder is designed so that it can be blocked, if the truck unexpectedly moves off, preventing the bay and any other element on its surface (operators, forklifts, etc.) from falling.

**7** All the components and the moving parts, lip and inferior structure are painted separately with an anti-corrosive primer followed by a coat of high-quality paint, thus ensuring a double 1+1 layer which guarantees 200% protective coating.



# DOCK SHELTERS



## DOCK SHELTERS

Retractable dock shelter, width 3400 x height 3400 x depth 600. The Flexidoor retractable dock shelter is designed for its use in warehouses, logistic centres and in any kind of productive plant, ensuring an important energy saving and good insulation as well as a better comfort and flexibility in the loading and unloading manoeuvres.

### DESCRIPTION

The dock shelter is formed by a perimeter structure that holds a joint of canvas which is adapted to the bodywork of the vehicle. This structure is retractable because in case of producing an incorrect manoeuvre by the vehicle, the dock shelter goes to its initial position without any damage. Its aim is to provide a perfect isolation at the moment of loading and unloading in such a way that it gets an important energy saving such and the consequent protection of goods.

## DIMENSIONS (mm)

DOCK SHELTERS	X	Y	Z
3200 x 3200	3200	3200	600
3200 x 3400	3200	3400	600
3200 x 3600	3200	3600	600
3200 x 4000	3200	4000	600
3200 x 4400	3200	4400	600
3400 x 3200	3400	3200	600
3400 x 3400	3400	3400	600
3400 x 3600	3400	3600	600
3400 x 4000	3400	4000	600
3400 x 4400	3400	4400	600



# DOCK SHELTERS



**COMPOSITION** The retractable dock shelter consists of the following elements:

## COVERS

Formed the joint of two lateral covers which take some serigraphy strips for helping with the vehicle manoeuvre and a superior cover forming the roof. These covers are manufactured by two polyester fabrics

with flexible wefts to facilitate the flexion and they are covered with black PVC and 3 mm of thickness. They are resistant to blows and scratching.

The superior cover has a reinforcement welded to avoid tears with the usage and to increase its durability.



## FLEXIBILITY AGAINST BLOWS (AND SCRATCHING) AND INSULATION

The retractable dock shelter cover is designed especially for providing an adding flexibility to the loading and unloading manoeuvres of vehicles of different dimensions. In the moment of goods transferring, it also isolates the installation from the exterior saving energy and increasing the comfort of the working area.



## SECURITY

All the dock shelters are supplied with reflective vertical bands to help the manoeuvre of carriers and to avoid collisions which could damage the installations and the vehicle as well. Flexidoor application tip Provide the bay area with truck guides on the floor. This form provides the truck is aligned to make it easier for it to enter correctly in the bay, so that the dock shelter seal isolate effectively and approximation damage are avoided.







The Flexidoor inflatable dock shelters are designed to ensure an optimal sealing during loading and unloading processes. The perfect adjustment to the truck box provides significant power saving by achieving thermic isolation from the exterior, and giving an improved hygiene inside the premises without any loss in comfort and flexibility in manoeuvring.

All the inflatable shelters are built in a 40mm panel structure, and a vertical strip of colour to facilitate the manoeuvres. Activated by an electric box, has a 220V-1 phase electric engine and a fan,

which allows inflating when the truck docks in the bay. The airbag folds in the laterals when the shelter is not working, to avoid tears and to ease the manoeuvres.

It is made in 3mm thickness PVC, highly resistant and waterproof, providing full air tightness in the laterals and the upper and inferior sides (with lower lateral bags).

All Flexidoor shelters strictly comply with the security rules in force, without forgetting our commitment to the environment.

# INFLATABLE DOCK SHELTERS



# ACCESSORIES

## DOCK BUMPERS AND CHOCKS



Small polyurethane bumper  
400x70x80



Small rubber bumper  
400x75x80



Large rubber bumper  
500x250x140



Manual wheel chock, the  
solution to block any truck



Automatic wheel chock



Manual wheel chock with sensor

## LOGISTICS SYSTEMS ACCESSORIES

As with the most product ranges, logistics systems also provide a wide range of accessories that aim to simplify the process of loading and unloading, making it safer, quickly and tranquillity.



Galvanized truck guides, it easier for it to enter the bay

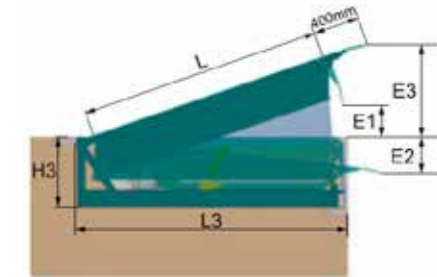
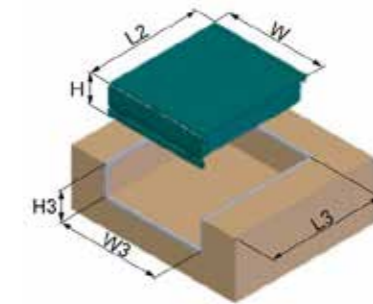

Standard sub-frame for RH11, 2000L x 2500W x 600H  
(pit 2580 x 2040). 6t.

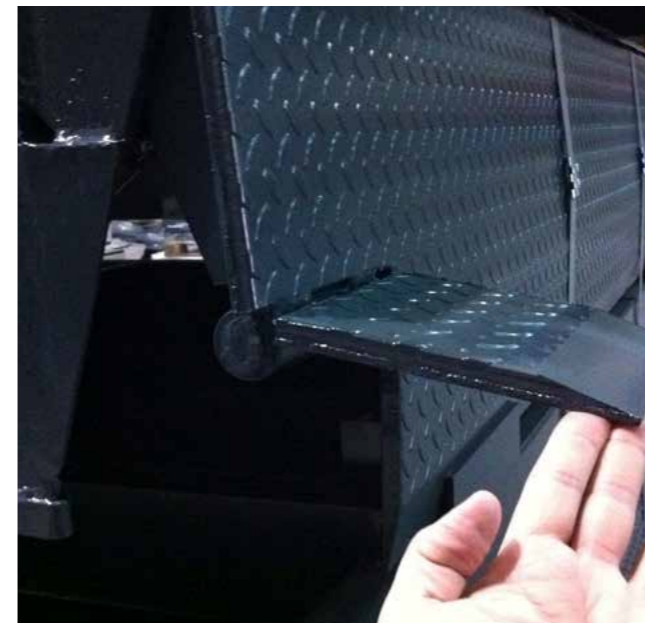

Segmented lips. The segmented lips are used to allow the lip to adapt to small and normal trucks.



Dock light. The dock light is the perfect accessory to illuminate the interior of the trucks during loading and unloading operations.



# MOTOR FOR INDUSTRIAL DOORS



LK75 / LK100



LKBOX75CHW  
LK100BOXDIGI



LKBOX75CH

	LK75	LK100
Working Voltage	230 V	400 V
Max. Door surface	25 m <sup>2</sup>	35 m <sup>2</sup>

## LK75/LK100 IS THE PROOF THAT SAFETY CAN BE REACHED

The LK model is specifically targeted to the market of industrial sectional doors. It was developed based on stringent technical and market studies, incorporating the latest technologies at our disposal,

as well as systems capable of meeting and satisfying all kinds of demands and needs in the industry sector.



LK100SOM



LK100SOM-HP



LK100BOXSOM

## Shaft Single-phase motor / Three-phase motor with Automatic or Dead Man Control Board

	LK100SOM + LK100BOXSOM	Single-phase motor	Trifásico
Working Voltage		230 V	400 V
Maximum Door surface		25 m <sup>2</sup>	35 m <sup>2</sup>

## Shaft Single-phase motor/ Three-phase motor with Integrated Dead Man Control Board

	LK100SOM-HP	Single-phase motor	Trifásico
Working Voltage		230 V	400 V
Maximum Door surface		25 m <sup>2</sup>	35 m <sup>2</sup>

# ACCESSORIES



## DIGIWIRELESS

The selectors LIKE IT offers the DIGIWIRELESS, a digital wireless key selector with Rolling code 433.92 MHz technology that is easily fixed on a wall for a regular utilization.



## FAST4

The new line of remote controls FAST4 are the perfect combination of factors like aesthetics, functionality and design, which added the elegance and versatility needed every day. The protective plastic, very resistant, ensures a perfect and lasting life.

FAST4	
Number of Channels	4
Encoding type	rolling-code
Transmission frequency	433,92MHz
Irradiated power	1mw
Encoding	64 bit
Maximum temperature	55°C
Capacity of signal	150-200m



## VIS

The VIS photocell is an optical sensor with transmitter and receiver that work by infrared signal to detect the presence of obstacles, which function is to stop and reverse the door movement before it collide with a person or object in the area of operation.



## EXT2

The external receiver EXT2 have 2-channel rolling-code 433.92 MHz with 999 codes memory with plug-in for multiple applications.



## WIRELESSBAND

Wireless pedestrian safety kit for automatic doors.





RUA DA MAJOEIRA, Nº 400  
APARTADO 542  
2415 - 184 REGUEIRA DE PONTES  
LEIRIA • PORTUGAL

TEL. +351 244 850 470

FAX. +351 244 850 471

INFO@FLEXIDOOR.PT

**WWW.FLEXIDOOR.PT**

CATIND.EN.09.17

DISTRIBUTOR

Cofinanciado por:

